

SIZE 20 - HELICAL INLINE GEARBOXES – REFERENCE CHART

MARCA	GRANDEZZA	ALB. USC. D	ALB. USC. L	a	b	H	FLANGE USC.	COPPIA MAX [N m]	CARICO RADIALE MAX IN USC. [N m]	i _{min} - i _{max}
SITI	NHL20/2	20/16	40/-	50	110	75	120/140/160	70	1800	4,32-49,14
MOTOVARIO	IHA 32/33	20/16/14	40/40/30	80	110-120	75	140/120	100	2000	5,38-347,29
NORD	SK 02/03	20	40	60	110	86	120/140/160	110	-	2,95-313,11
FLENDER	D./Z.18	20	40	110	110	75	120/140/160	90	1600	3,58-200,36
SEW	-	-	-	-	-	-	-	-	-	-
ROSSI	R 2I 32	16	30	53	115	75	140	37,5	1250	6,33-13,5
	R 2I 40	19	40	63	132	90	160	75	2000	6,08-40,40
	R 2I 41	24	36	63	132	90	160	95	2500	6,08-33,1
	STANDARD FIT R 2/3 I 0	20	40	95	85	65	-	56	1250	-
	STANDARD FIT R 2/3 I 1	20	40	110	110	75	-	95	1800	-
VARVEL	RD 02/03	17/20	35/40	95	80	60	120/140/160	50	1420	2,56-324,44
	RD 12/13	20/25	40/50	110	110	75	120/140/160	100	2200	2,53-624,41
STM	AR 25/2-3	11/14	22/25	71	90	63	105/120	22	650	3,4-86,2
	AR 35/2-3	16/19/20	30/40/40	87	110	85	140/160/200	60	1800	3,4-195,6
	AR 40/2-3	20/19/25	40/40/50	85	110	80	120/140/160/200	105	2700	8,5-181,4
BONFIGLIOLI	C 052	16	40	50	110	85	140	45	500	5,5-44,7
	C 112	20	40	50/37	110	85	120/140/160	100	2000	2,8-66,2
LEROY SOMER	CB 1702/1703	20	45	105-2 st 125-3 st	125	71	120/140/160	-	-	6,3-156,5
PUJOL	IP 84	16	34	88	78	84	120	38	1930	2,1-45,9
	IP 102	19	40	106	100	102	160	92	3550	2,3-47,0

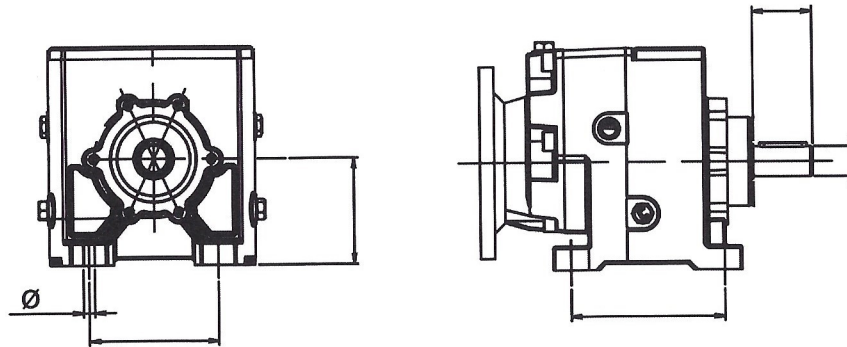

SIZE 25 - HELICAL INLINE GEARBOXES – REFERENCE CHART

MARCA	GRANDEZZA	ALB. USC. D	ALB. USC. L	a	b	H	FLANGE USC.	COPPIA MAX [N m]	CARICO RADIALE MAX [N m]	i _{min} - i _{max}
SITI	NHL25/2-3	25/24	50/50	130	110	90	120/160/200	160	4000	1,9-240,3
MOTOVARIO	IHA 42/43	25/19	50/40	85	110	80	160/140	150	4200	5,38-347,29
	IH 032/033	25	50	130	110	90	120/140/160/200	200	5500	4,70-245,70
NORD	SK 12/13	25	50	62	105	102	120/140/160	196	5100	2,96-420,83
FLENDER	D./Z.28	25	50	130	110	90	120/140/160	140	2890	3,33-241,5
	D./Z.38	30/25	60/50	130	110	90	120/140/160/200	220	6760	4,77-191,75
SEW	R27	25	50	130	110	90	120/140/160	130	4230	3,37-135,09
	R37	25	50	130	110	90	120/160/200	200	4950	3,41-134,82
ROSSI	R 2/3 I 50	24	50	76	124	106	160	160	3550	6,52-152
	R 2/3 I 51	28	42	76	124	106	160	224	4250	6,52-125
	STANDARD FIT R 2/3 I 2	25	50	130	110	90	-	150	4250	-
	STANDARD FIT R 2/3 I 3	25	50	130	110	90	-	224	5000	-
VARVEL	RD 22/23	25/30	50/60	130	110	90	140/160/200	200	3500	2,54-629,03
STM	AR 50/2-3	25/24/30	50/50/60	130	110	90	120/160/200/250	216	4300	6,3-146,9
BONFIGLIOLI	C 212/213	25	50	60/47,5	130	100	140/160/200	200	5000	2,7-261,0
PUJOL	IP 128	24	50	126	118	128	200	174	4800	2,2-47,6

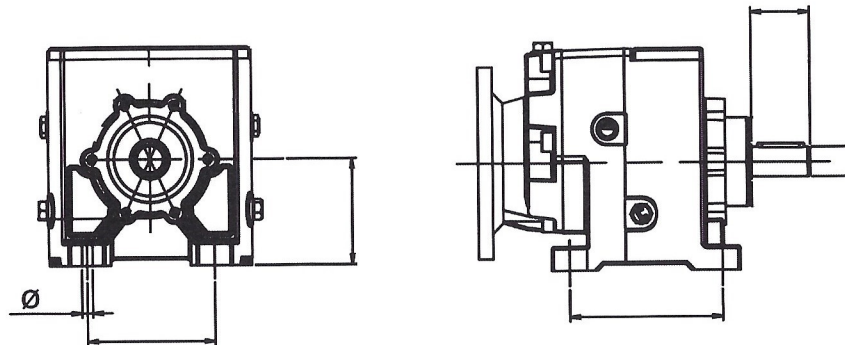

SIZE 30 - HELICAL INLINE GEARBOXES – REFERENCE CHART

MARCA	GRANDEZZA	ALB. USC. D	ALB. USC. L	a	b	H	FLANGE USC.	COPPIA MAX [N m]	CARICO RADIALE MAX [N m]	$i_{min} - i_{max}$
SITI	NHL30/2-3	30/28	60/60	165	135	115	160/200/250	350	5500	2,25- 466,86
MOTOVARIO	IHA 52/53	30/35/24	60/70/50	100	135-150	110	200/160	300	6000	5,14-353,98
	IH 042/043	30	60	165	135	115	120/140/160/200	300	6600	5,46-282,10
NORD	SK 22/23	30	60	80	160	125	160/200	340	7500	2,79-516,65
FLENDER	D./Z.48	40/30	80/60	165	135	115	200/250/300	450	8833	4,28-208,77
SEW	R47	30	60	165	135	115	140/160/200	300	5420	3,83-176,88
ROSSI	STANDARD FIT R 2I/3I 4	30	60	165	135	115	-	335	5300	-
	R 2I/3I 63	32	58	96	153	132	200	335	5300	6,36-154
	R 2I/3I 64	38	58	96	153	132	200	450	6700	6,36-120
VARVEL	RD 32/33	30/35	60/70	165	135	115	160/200/250	420	5000	2,69-646,00
STM	AR 60/2-3	30/28/35	60/60/70	165	135	115	160/200/250	460	6500	7,9-164,10
BONFIGLIOLI	C 312/313	30	60	70/60	160	110	160/200/250	300	5500	2,90-274,70
LERoy SOMER										
PUJOL	IP 142	28	60	145	130	142	200	287	5800	2,1-45,2

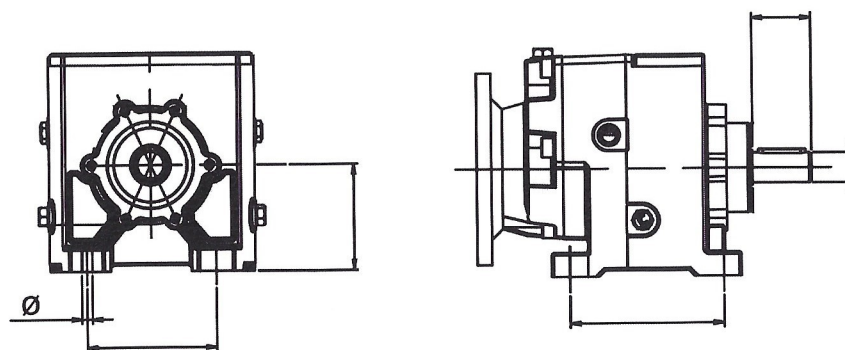

SIZE 35 - HELICAL INLINE GEARBOXES – REFERENCE CHART

MARCA	GRANDEZZA	ALB. USC. D	ALB. USC. L	a	b	H	FLANGE USC.	COPPIA MAX [N m]	CARICO RADIALE MAX IN USC. [N m]	$i_{min} - i_{max}$
SITI	NHL35/2-3	35	70	165	135	115	160/200/250	510	7000	5,12-439,92
MOTOVARIO	IHA 62/63	40/28	80/60	110	170-185	120	250/200	480	8000	5,14-353,98
	IH 052/53	35	70	165	135	115	200/250	500	8000	5,73-267,65
NORD	SK 32/33	40	80	120	185	155	200/250	672	-	2,96-740,37
FLENDER	D./Z.48	40/30	80/60	165	135	115		450	8833	4,28-208,77
SEW	R57	35	70	165	135	115	160/200/250	450	7110	4,39-186,89
	R67	35	70	195	150	130	200/250	600	7560	4,39-186,89
ROSSI	STANDARD FIT R 2I/3I 5	35	70	165	135	115	-	500	7100	-
	STANDARD FIT R 2I/3I 6	35	70	195	150	130	-	670	7500	-
	R 2I/3I 64	38	58	96	153	132	200	450	6700	6,36-120
	R 2I/3I 80	38	80	123	192	160	250	670	8000	6,1-203
VARVEL	RD 32/33	30/35	60/70	165	135	115	160/200/250	420	5000	2,69-646,00
	RD 42/43	35/40	70/80	195	150	130	200/250/300	630	8000	2,48-664,60
STM	AR 60/2-3	30/28/35	60/60/70	165	135	115	160/200/250	460	6500	7,9-164,1
BONFIGLIOLI	C 352/353/354	35	70	130	170	115	200/250	450	6500	2,7-848,5
	C 412/413/414	35	70	149,5	180	130	200/250	600	7000	2,7-855,5
PUJOL	IP 162	38	80	205	160	162	250	615	9200	2,2-45,6

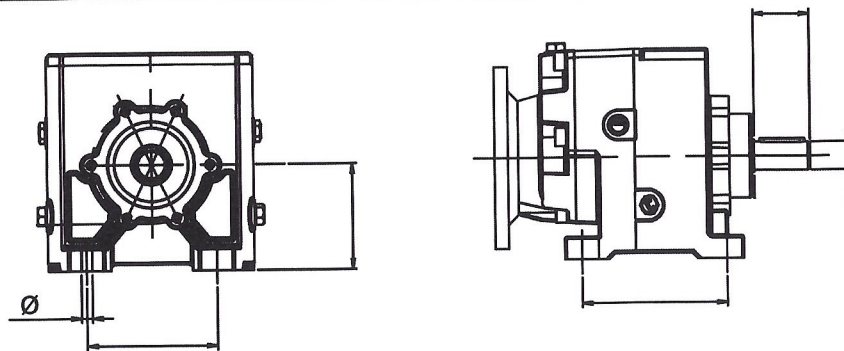

SIZ 40 - HELICAL INLINE GEARBOXES - REFERENCE CHART

MARCA	GRANDEZZA	ALB. USC. D	ALB. USC. L	a	b	H	FLANGE USC.	COPPIA MAX [N m]	CARICO RADIALE MAX [N m]	i _{min} - i _{max}
SITI	NHL40/2-3	40/38	80/80	205	170	140	250/300	600	9500	2,27-434,74
MOTOVARIO	IH 062/63	40	80	205	170	140	200/250/300	850	12000	5,38-268,00
NORD	SK 32/33	40	80	120	185	155	200/250	672	-	2,96-740,37
FLENDER	D./Z.68	50/40	100/80	205	170	140	250/300/350	800	14100	3,49-281,01
SEW	R67	35	70	195	150	130	200/250	600	7560	4,39-186,89
	R77	40	80	205	170	140	250/300	820	9920	5,31-195,24
ROSSI	STANDARD FIT R 2I/3I 6	35	70	195	150	130	-	670	7500	-
	STANDARD FIT R 2I/3I 7	40	80	205	170	140	-	900	10000	-
	R 2I/3I 80	38	80	123	192	160	250	670	8000	6,1-203
	R 2I/3I 81	48	80	123	192	160	250	900	10000	6,1-166
VARVEL	RD 42/43	35/40	70/80	195	150	130	200/250/300	630	8000	2,48-664,60
STM	AR 80/2-3	40/38	80/80	205	170	140	250/300	967	11000	7,8-171,2
BONFIGLIOLI	C 412/413/414	35	70	149,5	180	130	200/250	600	7000	2,7-855,5
	C 512/513/514	40	80	156	225	155	250/300	1000	10000	2,6-884,9
PUJOL	IP 162	38	80	205	160	162	250	615	9200	2,2-45,6
	SP 160	48	110	270	195	160	250/350	872	26000	4,6-467,4

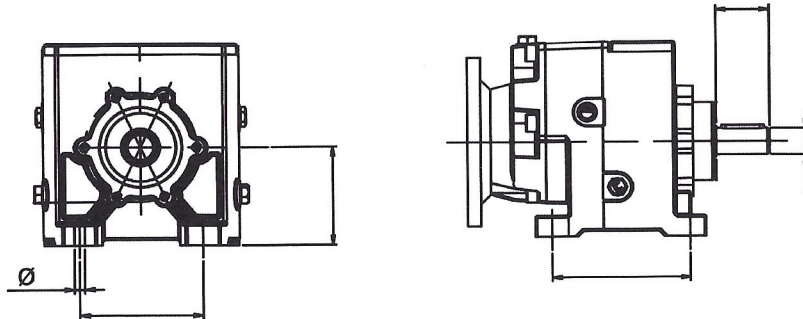

SIZE 50 - HELICAL INLINE GEARBOXES - REFERENCE CHART

MARCA	GRANDEZZA	ALB. USC. D	ALB. USC. L	a	b	H	FLANGE USC.	COPPIA MAX [N m]	CARICO RADIALE MAX [N m]	$i_{min} - i_{max}$
SITI	NHL50/2-3	50	100	260	215	180	300/350	1200	15000	3,07-464,96
MOTOVARIO	IH 082/83	50	100	260	215	180	250/300	1800	18000	5,39-222,78
NORD	SK42/43	45	90	120	175	175	200/250	1289	-	3,02-1071,82
FLENDER	D./Z.88	60/50	120/100	260	215	180	300/350/400	1680	23000	3,11-300,41
SEW	R 87	50	100	260	215	180	300/350	1550	16900	5,30-246,54
ROSSI	R 2I/3I 100	48	82	160	240	195	300	1320	12500	6,5-186,00
	R 2I/3I 101	55	82	160	240	195	300	1800	16000	6,5-153,00
VARVEL	-	-	-	-	-	-	-	-	-	-
STM	AR 100/2-3	50/48	100/100	260	215	180	300/350	1950	15000	2,4-161,80
BONFIGLIOLI	C 612/613/614	50	100	180	250	195	300/350	1600	16000	2,80-796,10
PUJOL	SP 180	50	110	295	220	180	300/400	1256	26000	4,6-443,8
	SP 195	55	110	320	240	195	300/450	1664	32000	4,9-455,5

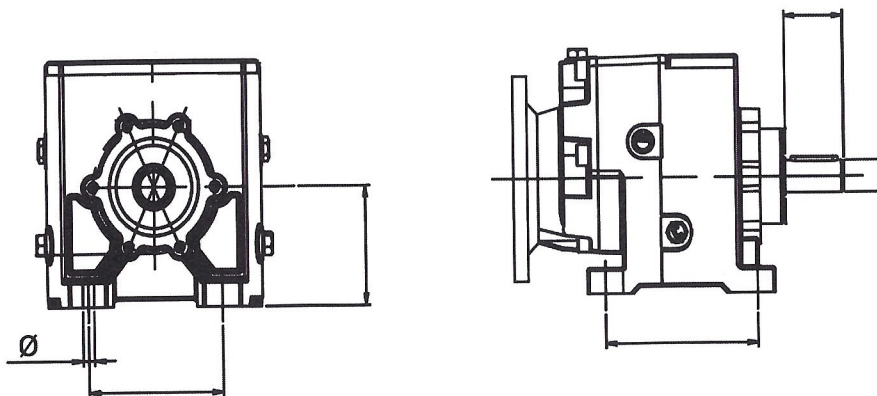

SIZE 60 - HELICAL INLINE GEARBOXES - REFERENCE CHART

MARCA	GRANDEZZA	ALB. USC. D	ALB. USC. L	a	b	H	FLANGE USC.	COPPIA MAX [N m]	CARICO RADIALE MAX [N m]	$i_{min} - i_{max}$
SITI	NHL60/2-3	60	120	310	250	225	350/450	2300	22000	3,76-358,47
MOTOVARIO	IH 102/103	60	120	310	250	225	300/350	3600	22000	5,26-242,59
NORD	SK52/53	55	110	150	220	212	250/300	2231	-	2,78-728,20
FLENDER	D./Z.108	70/60	140/120	310	250	225	350/450	3100	35216	3,42-359,30
SEW	R 97	60	120	310	250	225	350/450	3300	19800	4,50-289,74
ROSSI	R 2I/3I 125	60	105	200	297	236	350	2650	20000	6,35-187,00
	R 2I/3I 126	70	105	200	297	236	350	3550	25000	6,35-146,00
VARVEL	-	-	-	-	-	-	-	-	-	-
STM	AR 120/2-3	60	120	310	250	225	350/450	3300	25000	2,8-277,30
BONFIGLIOLI	C 702/703/704	60	120	165	300	210	350	2300	25000	4,6-1476
PUJOL	SP 218	60	140	350	270	218	350/450	2229	36000	4,8-445,5

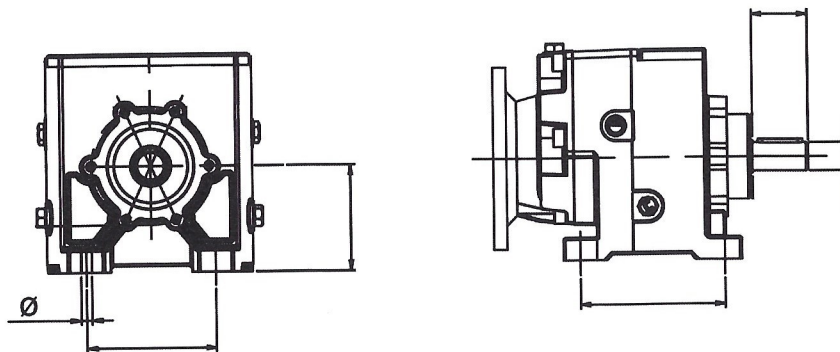

SIZE 70 - HELICAL INLINE GEARBOXES - REFERENCE CHART

MARCA	GRANDEZZA	ALB. USC. D	ALB. USC. L	a	b	H	FLANGE USC.	COPPIA MAX [N m]	CARICO RADIALE MAX [N m]	$i_{min} - i_{max}$
SITI	NHL 70/2-3	70	140	370	290	250	350/450	4000	29000	5,526-370,73
MOTOVARIO	IH 122/123	70	140	370	290	250	400	5000	30000	5,27-2302,92
NORD	SK 62/63	65	130	295	260	250	300	3700	-	2,97-372,21
	SK 72/73	75	140	330	325	280	350	5650	-	2,76-205,61
FLENDER	D./Z.128	90/70	170/140	370	290	250	350/450/500	5100	45052	3,07-268,16
SEW	R 107	70	140	370	290	250	350/450	4300	29500	4,92-251,15
ROSSI	R 2I/3I 126	70	105	200	297	236	350	3550	25000	6,35-146,00
	R 2I/3I 140	80	130	218	297	250	350	5000	31500	9,92-146,00
VARVEL	-	-	-	-	-	-	-	-	-	-
STM	-	-	-	-	-	-	-	-	-	-
BONFIGLIOLI	C 802/803/804	80	140	210	370	250	400	4000	35000	5,6-1481
PUJOL	SP 238	70	140	390	300	238	400/550	3076	49000	4,8-450,3
	SP 268	80	170	440	330	268	450/550	4237	62000	4,9-455,3

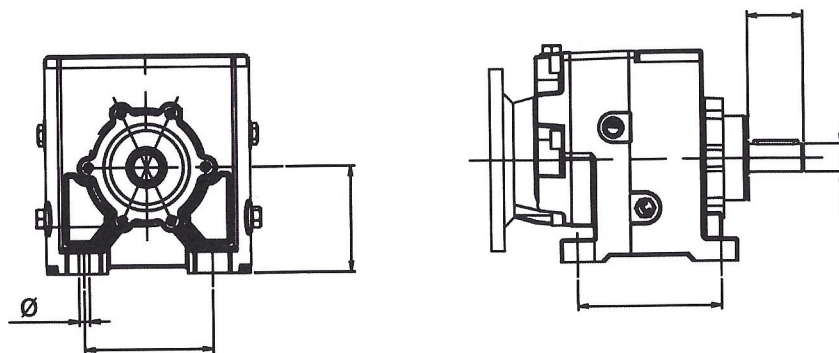

SIZE 90 - HELICAL INLINE GEARBOXES - REFERENCE CHART

MARCA	GRANDEZZA	ALB. USC. D	ALB. USC. L	a	b	H	FLANGE USC.	COPPIA MAX [N m]	CARICO RADIALE MAX [N m]	$i_{min} - i_{max}$
SITI	NHL 90/2-3	90	170	410	340	315	400/450	8000	32000	5,09-226,72
MOTOVARIO	IH 142/143	90	170	410	340	315	400/450	8000	55000	5,27-206,08
NORD	SK 82/83	90	170	400	360	315	450	9180	-	2,89-216,61
FLENDER	D./Z.148	100/90	210/170	410	340	315	450/500	8000	63750	4,44-336,11
SEW	R 137	90	170	410	340	315	450/550	8000	53400	5,15-222,60
ROSSI	R 2I/3I 160	90	130	250	373	295	450	7100	40000	6,34-119
VARVEL	-	-	-	-	-	-	-	-	-	-
STM	-	-	-	-	-	-	-	-	-	-
BONFIGLIOLI	C 902/903/904	90	170	250	440	300	450	7200	60000	5,2-1240
PUJOL	SP 302	90	170	490	360	302	450/660	5514	75000	4,6-452
	SP 330	100	210	530	400	330	550/660	7587	95000	4,8-512,8

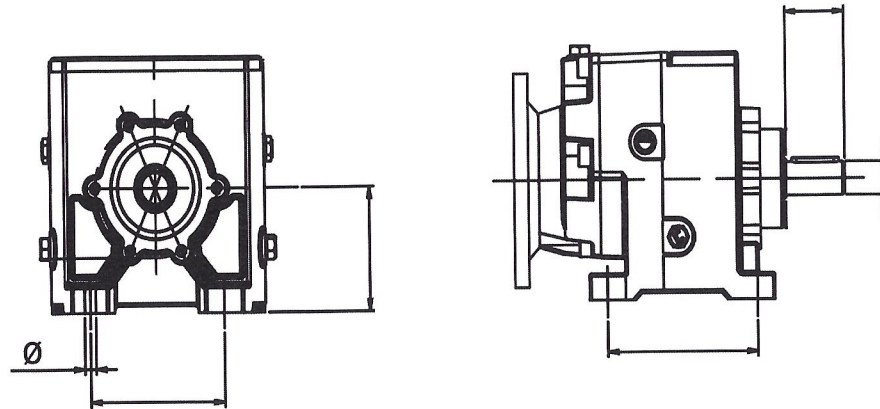

SIZE 100 - HELICAL INLINE GEARBOXES - REFERENCE CHART

MARCA	GRANDEZZA	ALB. USC. D	ALB. USC. L	a	b	H	FLANGE USC.	COPPIA MAX [N m]	CARICO RADIALE MAX [N m]	$i_{min} - i_{max}$
SITI	NHL 100/2-3	100	210	500	440	345	550	12000	52000	5,03-152,40
MOTOVARIO	-	-	-	-	-	-	-	-	-	-
NORD	SK 92/93	110	210	450	440	390	450	14000	-	3,51-187,89
FLENDER	D./Z.168	120/100	210/210	500	380	355	450/550/660	14000	86311	4,46-341,61
SEW	R 147	110	210	500	380	355	450/550	13000	62700	5,00-163,31
ROSSI	R 2I/3I 180	100	165	275	373	315	450	10000	50000	8,43-123
VARVEL	-	-	-	-	-	-	-	-	-	-
STM	-	-	-	-	-	-	-	-	-	-
BONFIGLIOLI	C 1002/1003/1004	100	210	290	490	345	550	12000	85000	4,90-1081
PUJOL	SP 360	110	210	570	430	360	550/800	9475	110000	4,6-527,1

